

BLUE RHINO CENTRIFUGAL FANS - SWSI

DIMENSIONS - BRB BOX TYPE

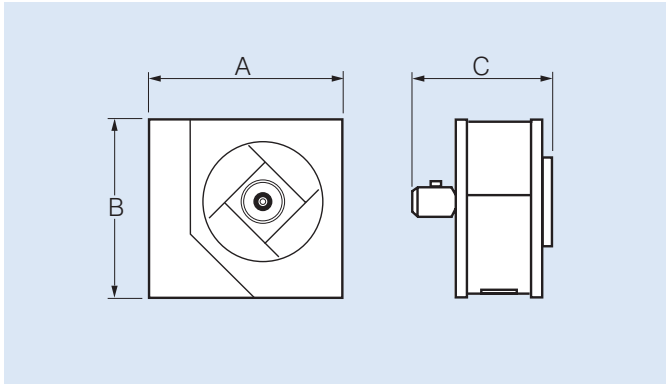

Model Number BRB..	Dimensions, mm			App. wt. kg
	A	B	C	
12-305LS-24	682	603	564	78
12-305LS-38	682	603	564	76
12-305LS-48	682	603	564	78
13-330LS-24	733	651	582	87
13-330LS-38	733	651	598	87
13-330LS-48	733	651	622	97
14-355LS-24	784	699	600	96
14-355LS-38	784	699	661	102
14-355LS-48	784	699	675	116
15-380LS-24	835	747	640	106
15-380LS-38	835	747	730	116
15-380LS-48	835	747	748	139
16-410LS-24	900	809	681	139
16-410LS-33	900	809	836	144
16-410LS-48	900	809	836	194
18-460LS-24	1020	908	744	190
18-460LS-29	1020	908	779	200
18-460LS-33	1020	908	808	198
20-510LS-22	1122	1004	851	222
20-510LS-24	1122	1004	835	231
20-510LS-29	1122	1004	855	250
22-560LS-16	1224	1100	838	255
22-560LS-22	1224	1100	902	264
22-560LS-24	1224	1100	902	283
22-560LS-29	1224	1100	993	295
24-610LS-16	1335	1196	909	307
24-610LS-22	1335	1196	994	328
24-610LS-24	1335	1196	1025	345
27-680LS-12	1473	1330	1022	369
27-680LS-16	1473	1330	1069	399
27-680LS-19	1473	1330	1109	411
27-680LS-22	1473	1330	1143	423
30-760LS-12	1640	1483	1162	500
30-760LS-16	1640	1483	1167	521
30-760LS-19	1640	1483	1224	539

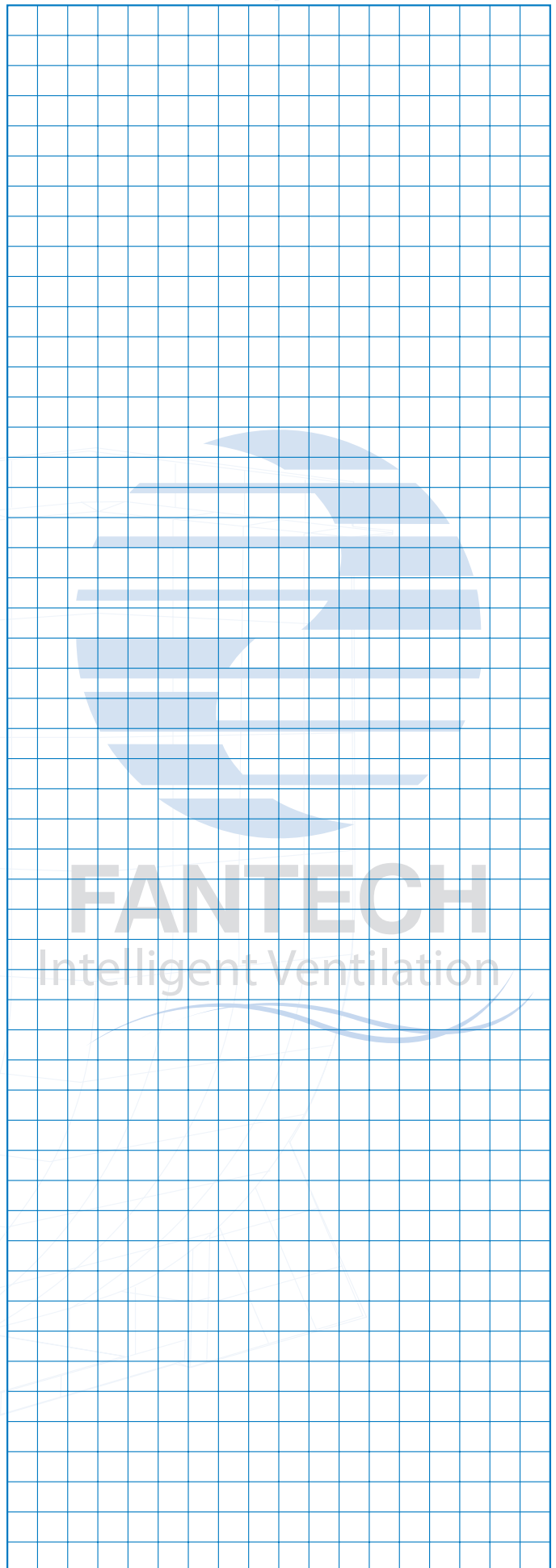

Scan the QR Code
to view more
information online.



Box Type

BLUE RHINO CENTRIFUGAL FANS - SWSI

PERFORMANCE CURVES - BRP PEDESTAL TYPE

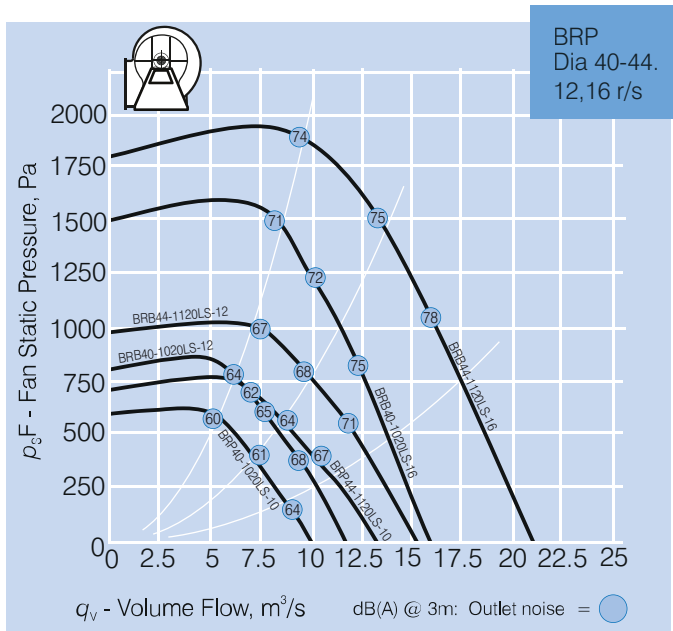
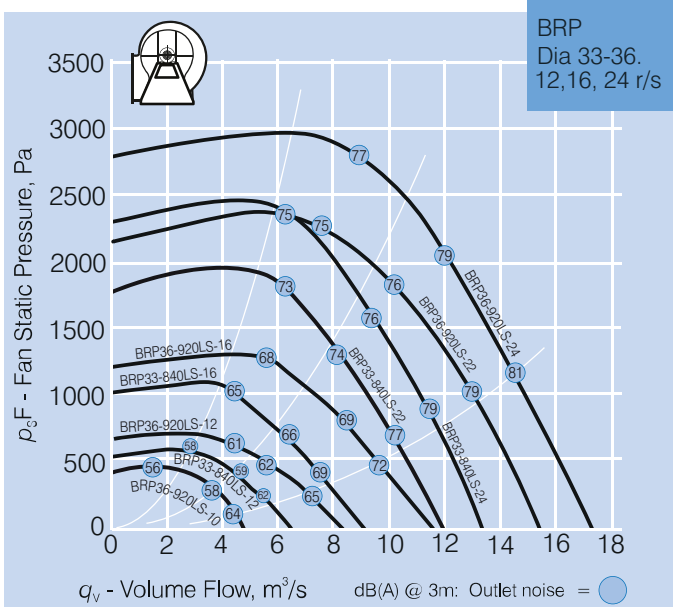
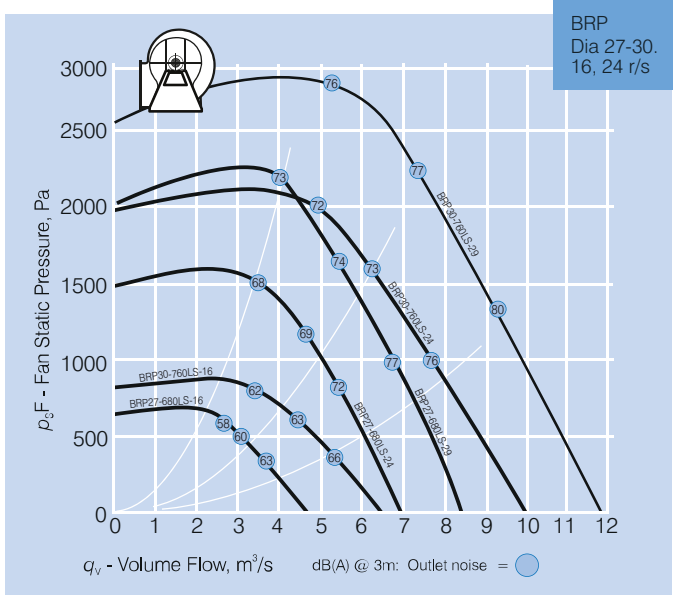

TECHNICAL DATA - BRP PEDESTAL TYPE

Model Number BRP..	Max. Speed rev/sec	Max Amps	Motor kW
27-680LS-16	16	7.6	3.0
27-680LS-24	24	21.5	11.0
27-680LS-29	29	27.6	15.0*
30-760LS-16	16	12.9	5.5
30-760LS-24	24	29.1	15.0
30-760LS-29	29	53	30.0*
33-840LS-12	12	7.9	3.0
33-840LS-16	16	16	7.5
33-840LS-22	22	32.8	18.5*
33-840LS-24	24	56.9	30.0
36-920LS-10	10	7	3.0*
36-920LS-12	12	14.7	5.5
36-920LS-16	16	23.4	11.0
36-920LS-22	22	53	30.0*
36-920LS-24	24	66.6	37.0
40-1020LS-10	10	12.8	5.5*
40-1020LS-12	12	17.7	7.5
40-1020LS-16	16	37.1	18.5
44-1120LS-10	10	16.4	7.5*
44-1120LS-12	12	34.3	15.0
44-1120LS-16	16	55	30.0

* Requires VSD - Cannot be run direct online (DOL).

BLUE RHINO CENTRIFUGAL FANS - SWSI

DIMENSIONS - BRP PEDESTAL TYPE

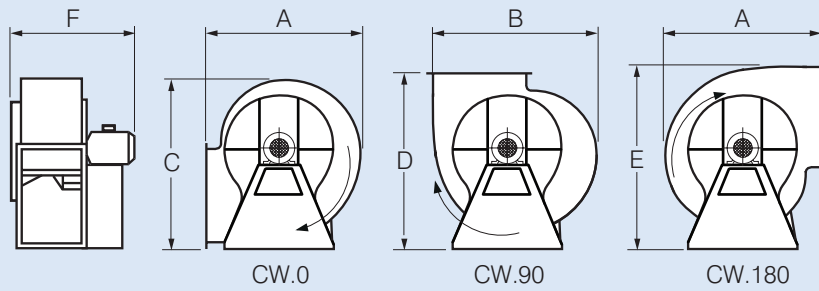

Direction of Rotation & Discharge Position

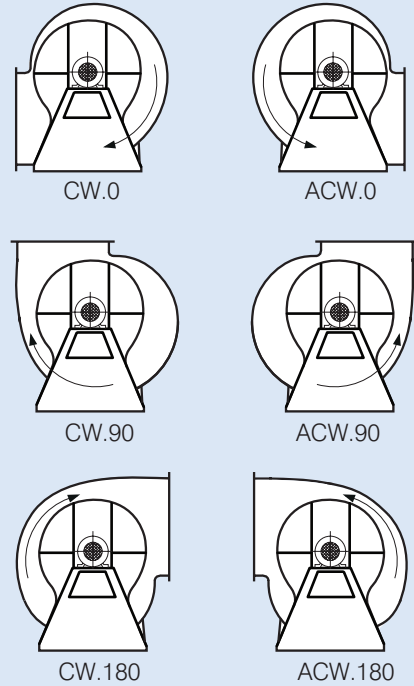

Model Number BRP..	Dimensions, mm						App. wt. kg
	A	B	C	D	E	F	
27-680LS-16	1314	1435	1436	1467	1699	1096	404
27-680LS-24	1314	1435	1436	1467	1699	1175	462
27-680LS-29	1314	1435	1436	1467	1699	1175	479
30-760LS-16	1467	1598	1605	1639	1893	1165	518
30-760LS-24	1467	1598	1605	1639	1893	1310	580
30-760LS-29	1467	1598	1605	1639	1893	1402	684
33-840LS-12	1621	1776	1774	1811	2102	1215	634
33-840LS-16	1621	1776	1774	1811	2102	1338	674
33-840LS-22	1621	1776	1774	1811	2102	1360	725
33-840LS-24	1624	1776	1774	1811	2102	1462	795
36-920LS-10	1773	1938	1943	1983	2295	1335	734
36-920LS-12	1773	1938	1943	1983	2295	1353	768
36-920LS-16	1773	1938	1943	1983	2295	1457	797
36-920LS-22	1773	1938	1943	1983	2295	1521	905
36-920LS-24	1773	1938	1943	1983	2295	1574	949
40-1020LS-10	1965	2141	2139	2183	2522	1445	908
40-1020LS-12	1965	2141	2139	2183	2522	1494	983
40-1020LS-16	1965	2141	2139	2183	2522	1596	1027
44-1120LS-10	2156	2344	2345	2393	2759	1574	1079
44-1120LS-12	2156	2344	2345	2393	2759	1670	1206
44-1120LS-16	2156	2344	2345	2393	2759	1722	1249



Scan the QR Code to view more information online.



Pedestal Type

PERFORMANCE CURVES - BRH HIGH PRESSURE TYPE

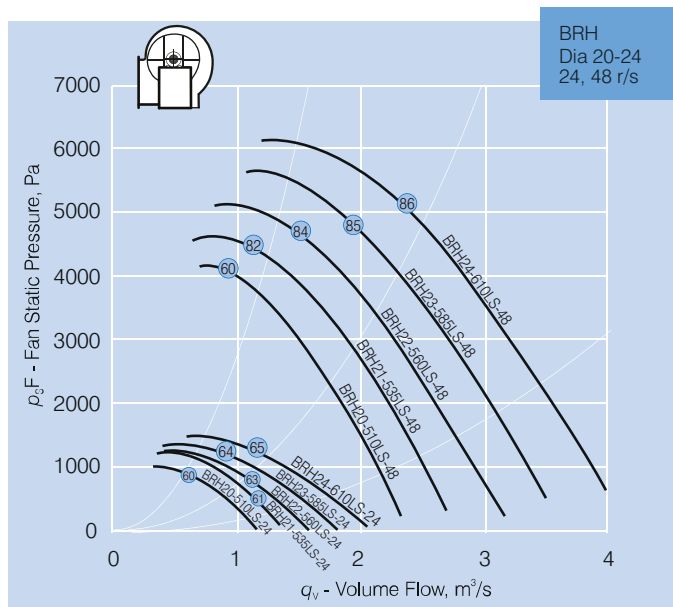
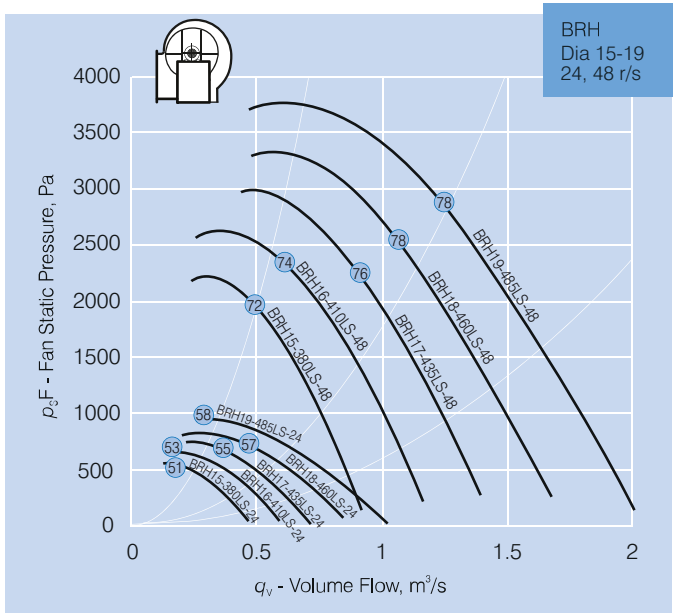
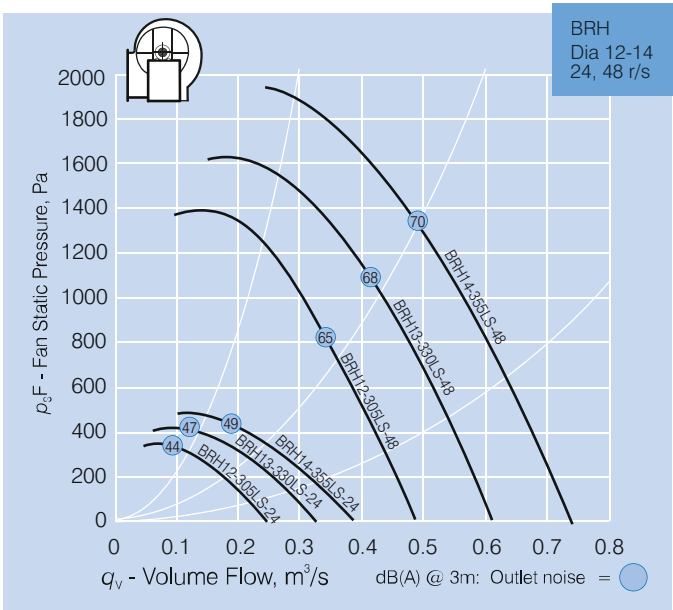

TECHNICAL DATA - BRH HIGH PRESSURE TYPE

Model Number BRH..	Max. Speed rev/sec	Max Amps	Motor kW
12-305LS-24	24	1.63	0.55
12-305LS-48	48	1.76	0.75
13-330LS-24	24	1.63	0.55
13-330LS-48	48	2.4	1.1
14-355LS-24	24	1.63	0.55
14-355LS-48	48	3.19	1.5
15-380LS-24	24	1.63	0.55
15-380LS-48	48	4.61	2.2
16-410LS-24	24	1.63	0.55
16-410LS-48	48	5.78	3
17-435LS-24	24	1.63	0.55
17-435LS-48	48	7.56	4
18-460LS-24	24	1.63	0.55
18-460LS-48	48	10.47	5.5
19-485LS-24	24	2.1	0.75
19-485LS-48	48	14.82	7.5
20-510LS-24	24	2.68	1.1
20-510LS-48	48	14.82	7.5
21-535LS-24	24	3.44	1.5
21-535LS-48	48	20.62	11
22-560LS-24	24	3.44	1.5
22-560LS-48	48	27.77	15
23-585LS-24	24	4.7	2.2
23-585LS-48	48	27.77	15
24-610LS-24	24	6.34	3
24-610LS-48	48	34.5	18.5

* Requires VSD - Cannot be run direct online (DOL).

BLUE RHINO CENTRIFUGAL FANS - SWSI

DIMENSIONS - BRH PEDESTAL HIGH PRESSURE TYPE

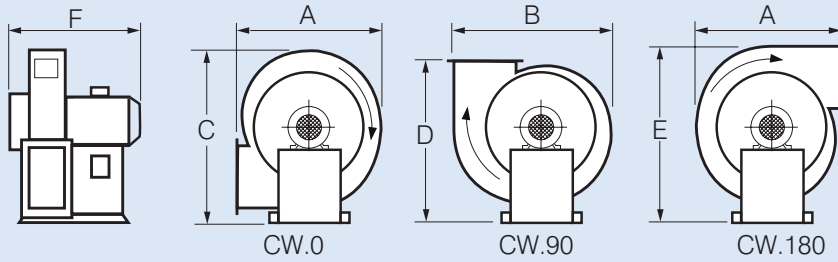

Direction of Rotation & Discharge Position

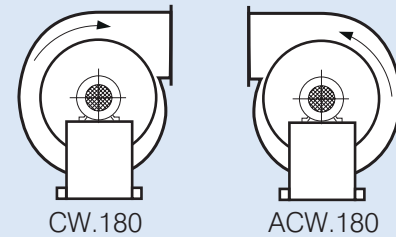
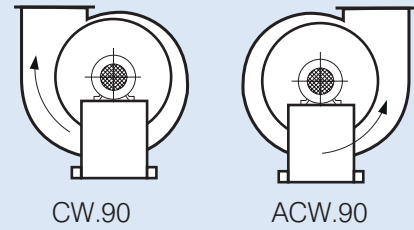
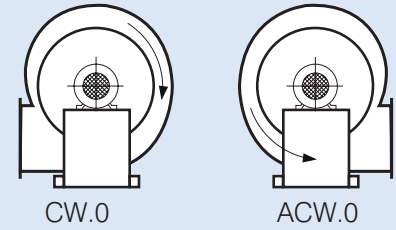

Model Number BRH..	Dimensions, mm						App. wt. kg
	A	B	C	D	E	F	
12-305LS-24	526	586	604	594	684	461	65
12-305LS-48	526	586	604	594	684	461	63
13-330LS-24	566	628	650	642	738	471	72
13-330LS-48	566	628	650	642	738	470	72
14-355LS-24	609	684	699	690	801	481	80
14-355LS-48	609	684	699	690	801	501	86
15-380LS-24	651	730	749	738	855	509	87
15-380LS-48	651	730	749	738	855	554	98
16-410LS-24	701	782	806	797	920	521	99
16-410LS-48	833	930	874	855	1000	630	123
17-435LS-24	743	828	855	844	973	531	108
17-435LS-48	743	828	855	844	973	626	146
18-460LS-24	786	874	905	893	1027	541	129
18-460LS-48	786	874	905	893	1027	668	187
19-485LS-24	833	930	960	941	1086	555	145
19-485LS-48	833	930	960	941	1086	730	211
20-510LS-24	869	972	1001	990	1145	605	162
20-510LS-48	869	972	1001	990	1145	756	222
21-535LS-24	911	1018	1050	1037	1198	636	180
21-535LS-48	911	1018	1050	1037	1198	836	289
22-560LS-24	954	1064	1100	1086	1252	648	195
22-560LS-48	954	1064	1100	1086	1252	848	313
23-585LS-24	996	1110	1150	1134	1306	684	225
23-585LS-48	996	1110	1150	1134	1306	854	330
24-610LS-24	1037	1152	1196	1183	1360	694	242
24-610LS-48	1037	1152	1196	1183	1360	913	360



Scan the QR Code to view more information online.



High Pressure Type